

Team Comp

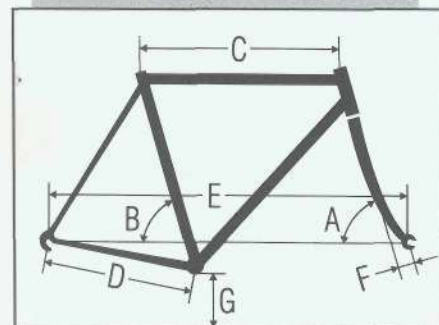

FRAME SIZE	A	B	C	D	E	F	G
18	69°	74°	22	17.0	42.1	1.8	11.5
19	69°	74°	22.3	17.0	42.4	1.8	11.5
20	69°	74°	22.7	17.0	42.8	1.8	11.5
21	69°	74°	23	17.0	43.1	1.8	11.5
22	69°	74°	23.3	17.0	43.4	1.8	11.5
23	69°	74°	23.7	17.0	43.8	1.8	11.5

The TEAM COMP has been a winner since its introduction at the 1983 Rock-hopper race. In that event, the first 5 places were captured by this revolutionary off-road design. Built with TOM RITCHEY'S specially designed competition tube set, the TEAM COMP has been a design often imitated, but never equalled. The seat tube has a 74° angle, giving the competitive rider a position similar to a road racing position. The head angle is 69°, allowing full control in any situation. In short, a perfect balance of handling and acceleration capabilities. This is a bicycle without compromise. Only the finest components were selected, including hand fillet brazed TWIN-STRUT handlebar, SUNTOUR XC Comp pedals and seatpost, DURA-ACE quick release hub, WHEELSMITH spokes, ARAYA RM 20 rims, and the new RITCHEY FORCE 1.9 tire. Six sizes from 18" to 23" are available in DUPONT IMRON Team Red. An exact replica of the machine used by the successful RITCHEY Mountain Bikes Team, including STEVE COOK and MAX JONES, we consider the TOM RITCHEY built TEAM COMP our signature model. If you're looking for an invigorating competition bicycle, the TEAM COMP is for you. ●



RITCHEY TEAM COMP™ / SPECIFICATIONS

FRAME	Designed and Built by TOM RITCHEY, using RITCHEY/COLUMBUS Double-Butted Chrome Molybdenum or TANGE PRESTIGE Off Road Tubing.
FORK	Designed and Built by TOM RITCHEY, using RITCHEY 4130 Chrome Molybdenum UNIFORK Blades.
BRAZE-ONS	Double Water Bottle Bosses, Special Slotted Cable Stops and Guides. Cantilever Bosses Front and Rear. Dropout Eyelets Front and Rear. Additional Braze-On Options Available.
HANDLEBAR	Designed and Built by TOM RITCHEY, Model III Chromoly TWINSTRUT with RITCHEY Double Expander.
SADDLE	SPECIALIZED Delta.
SEATPOST	SUNTOUR XC 300mm.
SEATPOST BOLT	SUNTOUR QR-170.
HEADSET	SHIMANO 600 EX.
BOTTOM BRACKET	SHIMANO 600 EX Sealed with Chromoly Axle.
CRANKSET	SHIMANO 600 EX Triple. 48/38/28. Crank Length matched to Frame Size.
PEDALS	SUNTOUR XC COMP.
REAR DERAILLEUR	SHIMANO DEORE XT.
FRONT DERAILLEUR	SHIMANO DEORE XT.
SHIFT LEVERS	SHIMANO DEORE XT.
BRAKES	SHIMANO DEORE XT Cantilevers.
BRAKE LEVERS	MAGURA "Shorty" with Covers.
HUBS	SHIMANO NEW DURA-ACE Low Flange Quick Release Cassette 6 Speed.
RIMS	ARAYA RM 20.
SPOKES	WHEELSMITH 14G Stainless.
TIRES	RITCHEY FORCE 1.9.
CHAIN	SHIMANO UNIGLIDE.
WEIGHT	26 lbs.
SIZES	18", 19", 20", 21", 22", 23". (Center to Top)
COLOR	TEAM RED.

ULTRA

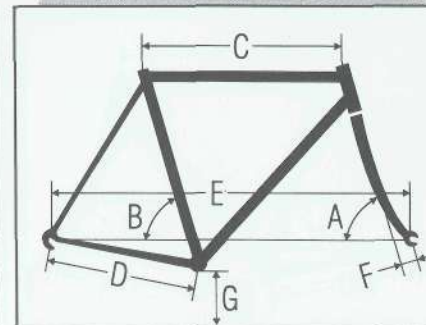

FRAME SIZE	A	B	C	D	E	F	G
17	69°	73°	21.5	17.4	41.8	2.0	11.5
18.5	69°	73°	22	17.4	42.3	2.0	11.5
20	69°	73°	22.5	17.4	42.8	2.0	11.5
21.5	69°	73°	23	17.4	43.3	2.0	11.5
23	69°	73°	23.5	17.4	43.8	2.0	11.5

The newest in a series of competition bicycles from TOM RITCHEY, the ULTRA is a startling blend of new technology and exciting aesthetic appeal. The TIG welded frameset is handcrafted with the new ultra-light TANGE PRESTIGE tubing, giving you the weight of an aluminum bike with the characteristic positive response of chromoly steel. The ULTRA uses the RITCHEY racing geometry of the TEAM COMP with a 74° seat angle and a 69° head angle. This is a hybrid machine designed for experienced riders who demand a first class bicycle. The ULTRA delivers excitement on all types of surfaces with the same component group as the TEAM COMP, black anodized wherever possible. Combined with a pearlescent white frame and fork, the look is lightweight, clean, and mean. Sizing is from 17" through 21.5" on this dynamic addition to the complete line of RITCHEY performance mountain bikes. ●

RITCHEY ULTRA™ / SPECIFICATIONS

FRAME	Designed by TOM RITCHEY, built using TANGE PRESTIGE Heat-Treated Chrome Molybdenum Frame Tubing.
FORK	Designed by TOM RITCHEY, built using RITCHEY 4130 Chrome Molybdenum UNIFORK Blades.
BRAZE-ONS	Double Water Bottle Bosses, Special Slotted Cable Stops and Guides. Front Cantilever Bosses, Rear "Roller Cam" Bosses, Dropout Eyelets Front and Rear.
HANDLEBAR	RITCHEY Design Model II Black Alloy Heat-Treated TWINSTRUT.
SADDLE	SPECIALIZED Delta.
SEATPOST	SUNTOUR XC 300mm.
HEADSET	SHIMANO 600 EX.
BOTTOM BRACKET	SHIMANO 600 EX Sealed with Chromoly Axle.
CRANKSET	SHIMANO 600 EX Triple. 48/38/28. Crank Length matched to Frame Size. Black Arms/Silver Rings.
PEDALS	SUNTOUR XC Comp Black. Toe Clips and Straps.
REAR DERAILLEUR	SHIMANO DEORE XT.
FRONT DERAILLEUR	SHIMANO DEORE XT.
SHIFT LEVERS	SHIMANO DEORE XT Black.
BRAKES	SHIMANO DEORE XT Black Front Cantilever. SUNTOUR XC SPORT "Roller Cam" Black on Chainstays.
BRAKE LEVERS	SUNTOUR XC SPORT.
HUBS	SHIMANO NEW DURA-ACE Low Flange Quick Release Cassette 6 Speed.
RIMS	ARAYA RM 20 Black.
SPOKES	WHEELSMITH 14G Stainless.
TIRES	RITCHEY QUAD 1.9.
FREEWHEEL	SHIMANO Cassette 12-28 6 Speed.
CHAIN	SHIMANO UNIGLIDE.
WEIGHT	25.5 lbs.
SIZES	17", 18.5", 20", 21.5". (Center to Top)
COLOR	PEARL WHITE With Black Twinstrut Handlebar.